

### M-5 SLAKER SPECIFICATIONS

DRUM SHELL 3/16"  
 DRUM LINER 1/4"  
 WATER JACKET 10 GA.  
 END PLATES 1/4"  
 BREAKER BARS 3/4" x 3/4"  
 HARDENED STEEL  
 293/391 BRINELL  
 NET VOLUME 12 CU. FT.  
 90 GALLONS  
 CaO/HR. 1000 LBS.  
 WATER 8 GPM  
 INLET 1"  
 DRIVE 1.5 HP  
 NET SLAKER WEIGHT 2219 LBS.  
 NET SCREEN WEIGHT 211 LBS.  
 NET FEEDER WEIGHT 375 LBS.

### M-15 SLAKER SPECIFICATIONS

DRUM SHELL 3/16"  
 DRUM LINER 1/4"  
 WATER JACKET 10 GA.  
 END PLATES 1/4"  
 BREAKER BARS 3/4" x 3/4"  
 HARDENED STEEL  
 293/391 BRINELL  
 NET VOLUME 28 CU. FT.  
 210 GALLONS  
 CaO/HR. 2500 LBS.  
 WATER 20 GPM  
 INLET 1"  
 DRIVE 2 HP  
 NET SLAKER WEIGHT 3155 LBS.  
 NET SCREEN WEIGHT 211 LBS.  
 NET FEEDER WEIGHT 375 LBS.

### M-25 SLAKER SPECIFICATIONS

DRUM SHELL 3/16"  
 DRUM LINER 1/4"  
 WATER JACKET 10 GA.  
 END PLATES 1/4"  
 BREAKER BARS 3/4" x 3/4"  
 HARDENED STEEL  
 293/391 BRINELL  
 NET VOLUME 60 CU. FT.  
 450 GALLONS  
 CaO/HR. 5500 LBS.  
 WATER 43 GPM  
 INLET 1-1/2"  
 DRIVE 5 HP  
 NET SLAKER WEIGHT 4428 LBS.  
 NET SCREEN WEIGHT 339 LBS.  
 NET FEEDER WEIGHT 375 LBS.

## DROP-IN RETROFIT SKID

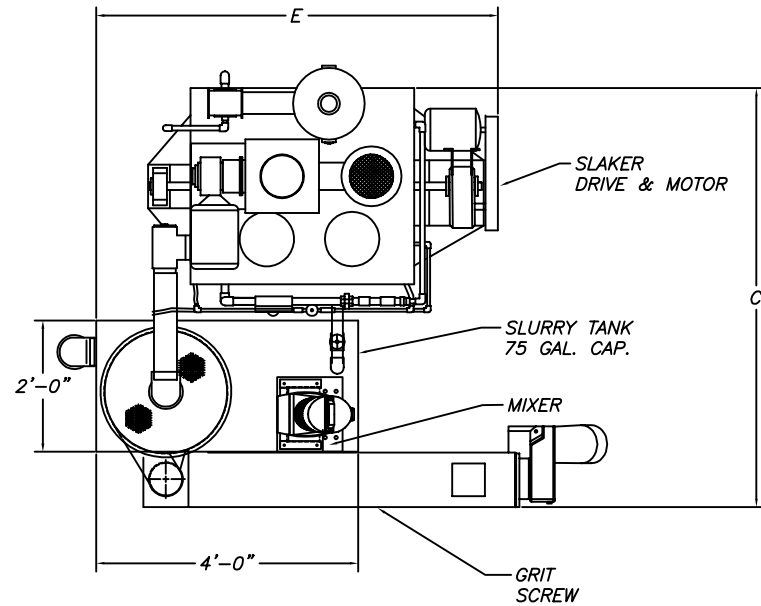

TOP VIEW

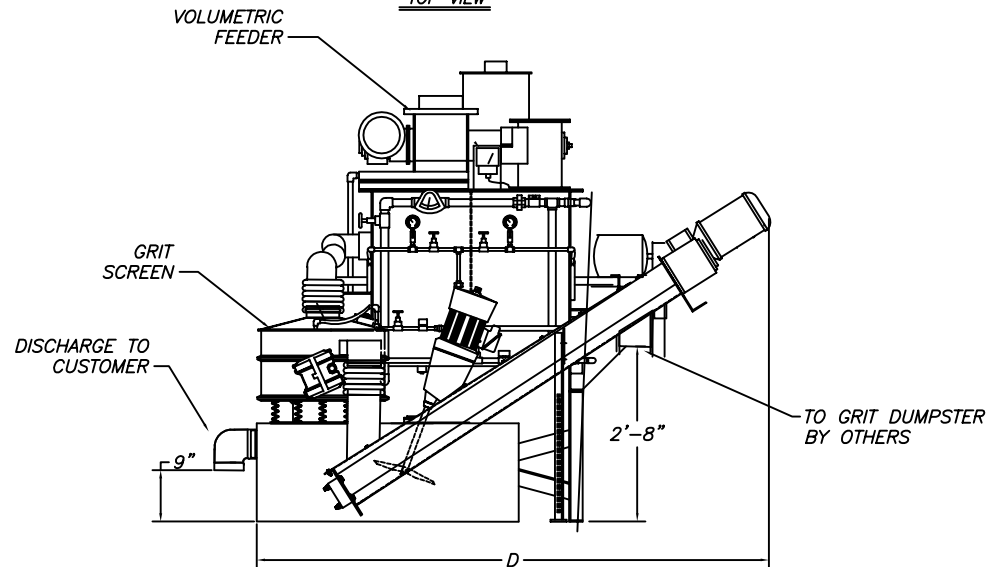

SIDE VIEW